

## 30V Dual P-Ch Power MOSFET

### Feature

- ◇ High Speed Power Switching, Logic Level
- ◇ Enhanced Avalanche Ruggedness
- ◇ 100% UIS Tested, 100% Rg Tested
- ◇ Lead Free, Halogen Free

$V_{DS}$		-30	V
$R_{DS(on),typ}$	$V_{GS}=-10V$	40	$m\Omega$
$R_{DS(on),typ}$	$V_{GS}=-5V$	65	$m\Omega$
$I_D$ (Silicon Limited)		-5	A

### SOIC-8

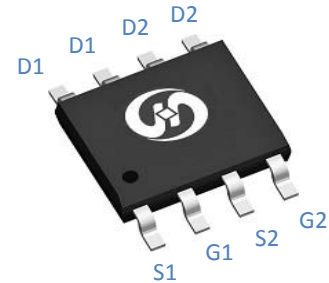

### Application

- ◇ Hard Switching and High Speed Circuit
- ◇ DC/DC in Telecoms and Industrial

Part Number	Package	Marking
HTS500B03	SOIC-8	TS500B03

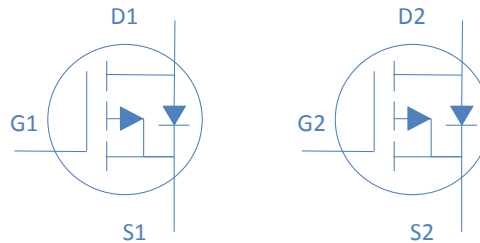

### Absolute Maximum Ratings at $T_j=25^\circ\text{C}$ (unless otherwise specified)

Parameter	Symbol	Conditions	Value	Unit
Continuous Drain Current (Silicon Limited)	$I_D$	$T_C=25^\circ\text{C}$	-5	A
		$T_C=100^\circ\text{C}$	-4	
Drain to Source Voltage	$V_{DS}$	-	-30	V
Gate to Source Voltage	$V_{GS}$	-	$\pm 20$	V
Pulsed Drain Current	$I_{DM}$	-	-20	A
Avalanche Energy, Single Pulse	$E_{AS}$	$L=0.1\text{mH}, T_C=25^\circ\text{C}$	3.20	mJ
Power Dissipation	$P_D$	$T_A=25^\circ\text{C}$	2.0	W
Operating and Storage Temperature	$T_J, T_{stg}$	-	-55 to 150	$^\circ\text{C}$

### Absolute Maximum Ratings

Parameter	Symbol	Max	Unit
Thermal Resistance Junction-Ambient	$R_{\theta JA}$	62.5	$^\circ\text{C/W}$
Thermal Resistance Junction-Case	$R_{\theta JC}$	25	$^\circ\text{C/W}$

**Electrical Characteristics at  $T_j=25^{\circ}\text{C}$  (unless otherwise specified)**
**Static Characteristics**

Parameter	Symbol	Conditions	Value			Unit
			min	typ	max	
Drain to Source Breakdown Voltage	$V_{(BR)DSS}$	$V_{GS}=0V, I_D=-250\mu A$	-30	-	-	V
Gate Threshold Voltage	$V_{GS(th)}$	$V_{GS}=V_{DS}, I_D=-250\mu A$	-1.0	-1.5	-3.0	
Zero Gate Voltage Drain Current	$I_{DSS}$	$V_{GS}=0V, V_{DS}=-24V, T_j=25^{\circ}\text{C}$	-	-	-1	$\mu A$
		$V_{GS}=0V, V_{DS}=-20V, T_j=125^{\circ}\text{C}$	-	-	-10	
Gate to Source Leakage Current	$I_{GSS}$	$V_{GS}=\pm 20V, V_{DS}=0V$	-	-	$\pm 100$	nA
Drain to Source on Resistance	$R_{DS(on)}$	$V_{GS}=-10V, I_D=-5A$	-	40	50	m $\Omega$
		$V_{GS}=-5V, I_D=-4A$	-	65	80	
Transconductance	$g_{fs}$	$V_{DS}=-5V, I_D=-5A$	-	16	-	S

**Dynamic Characteristics**

Input Capacitance	$C_{iss}$		-	820	-	pF
Output Capacitance	$C_{oss}$	$V_{GS}=0V, V_{DS}=-15V, f=1\text{MHz}$	-	122	-	
Reverse Transfer Capacitance	$C_{rss}$		-	97	-	
Total Gate Charge	$Q_g (10V)$		-	9.0	-	nC
Gate to Source Charge	$Q_{gs}$	$V_{DD}=-15V, I_D=-5A, V_{GS}=-10V$	-	2.2	-	
Gate to Drain (Miller) Charge	$Q_{gd}$		-	2.5	-	
Turn on Delay Time	$t_{d(on)}$		-	5.5	-	ns
Rise time	$t_r$	$V_{DD}=-15V, I_D=-1A, V_{GS}=-10V,$	-	10	-	
Turn off Delay Time	$t_{d(off)}$	$R_G=6\Omega,$	-	18	-	
Fall Time	$t_f$		-	15	-	

**Reverse Diode Characteristics**

Diode Forward Voltage	$V_{SD}$	$V_{GS}=0V, I_F=-2.3A$	-		-1.3	V
Reverse Recovery Time	$t_{rr}$	$I_F=-2.3A, di_F/dt=100A/\mu s$	-	15	-	ns
Reverse Recovery Charge	$Q_{rr}$		-	8	-	nC

Fig 1. Typical Output Characteristics

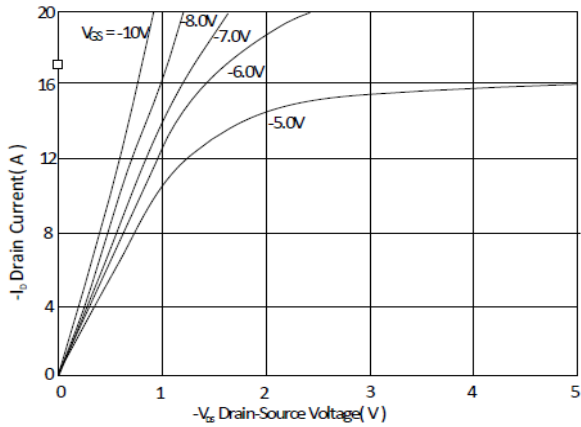

Figure 2. On-Resistance vs. Gate-Source Voltage

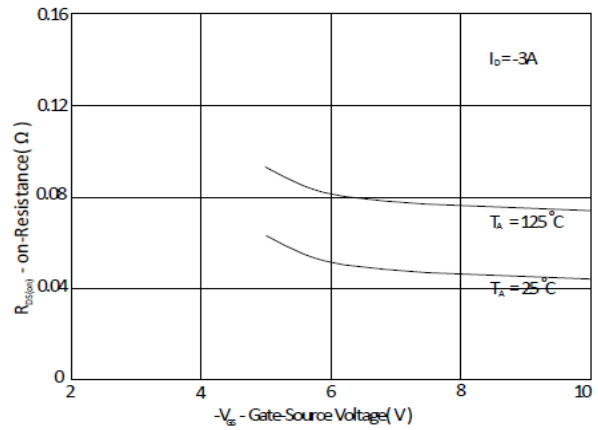

Figure 3. On-Resistance vs. Drain Current and Gate Voltage

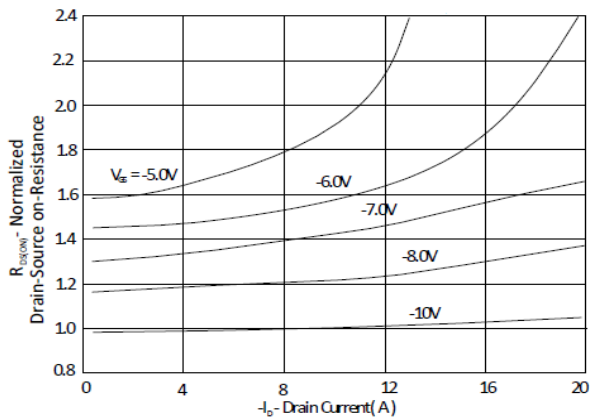

Figure 4. Normalized On-Resistance vs. Junction Temperature

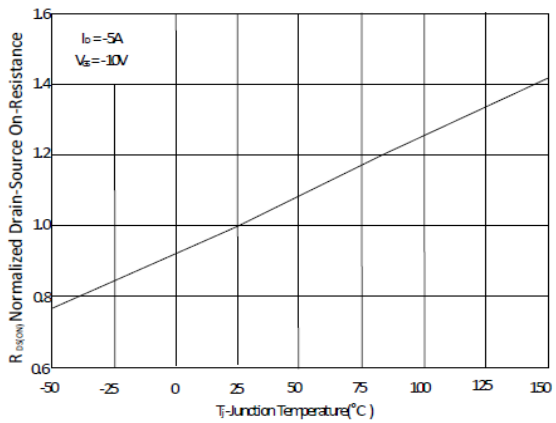

Figure 5. Typical Transfer Characteristics

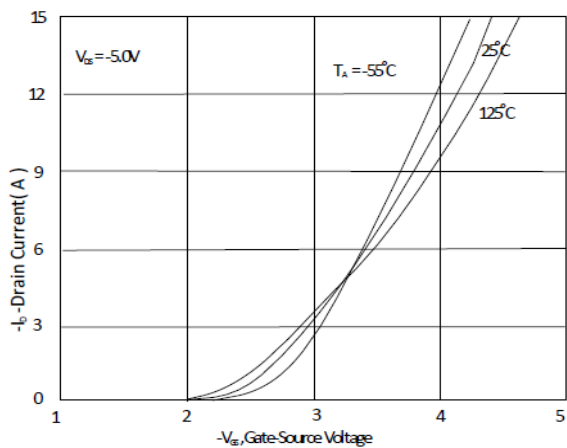

Figure 6. Typical Source-Drain Diode Forward Voltage

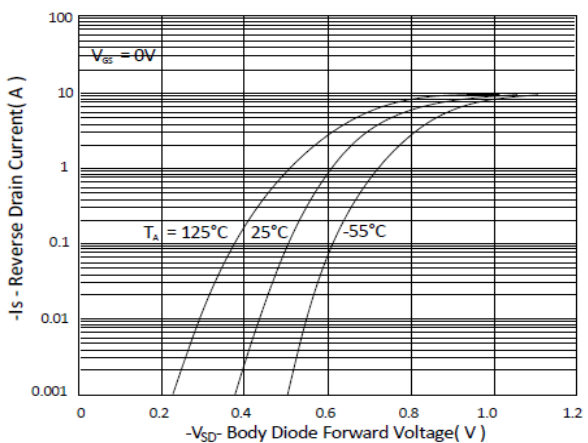

Figure 7. Typical Gate-Charge vs. Gate-to-Source Voltage

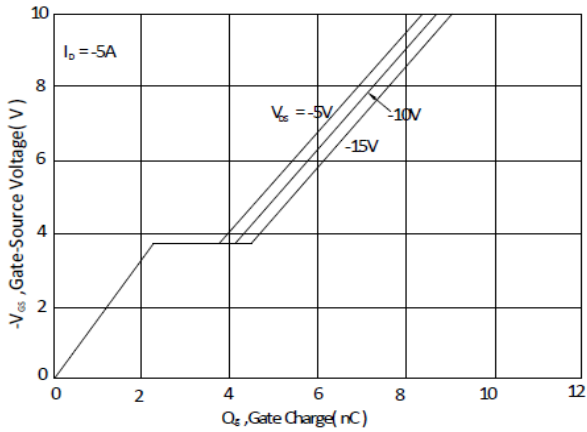

Figure 8. Typical Capacitance vs. Drain-to-Source Voltage

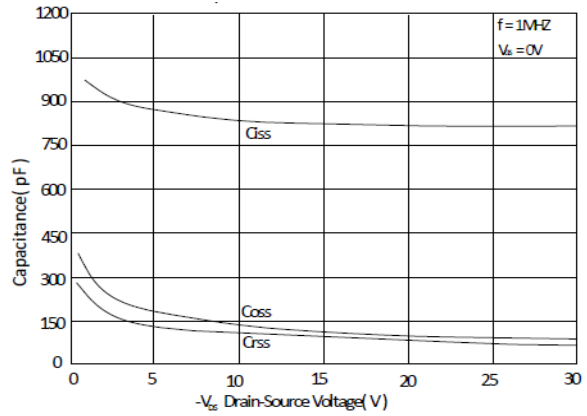

Figure 9. Maximum Safe Operating Area

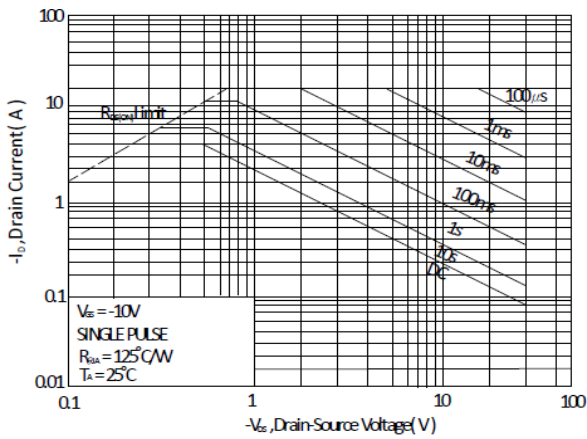

Figure 10. Single Pulse Maximum Power Dissipation

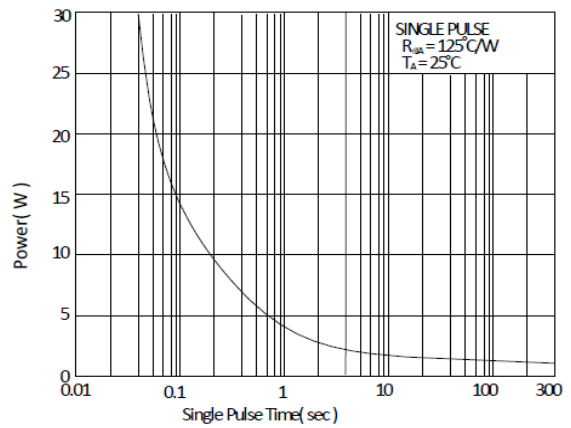
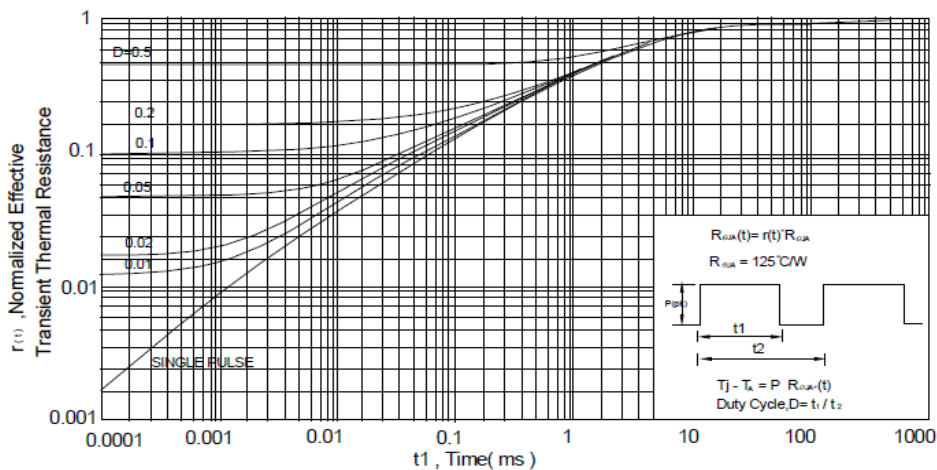
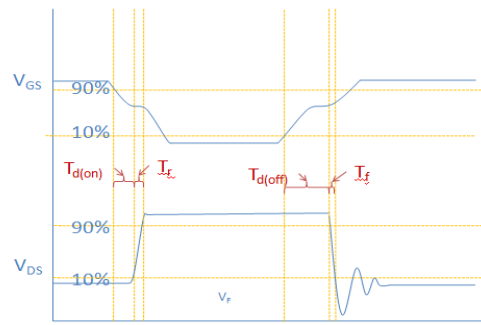
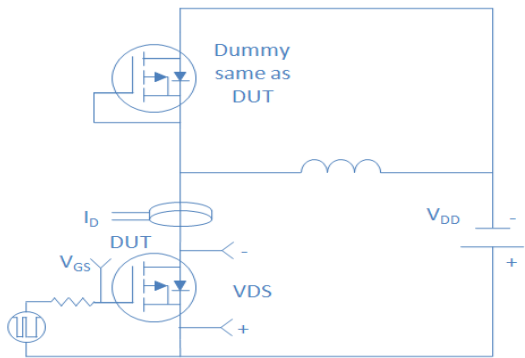

Figure 11. Normalized Maximum Transient Thermal Impedance, Junction-to-Ambient



Inductive switching Test



Gate Charge Test

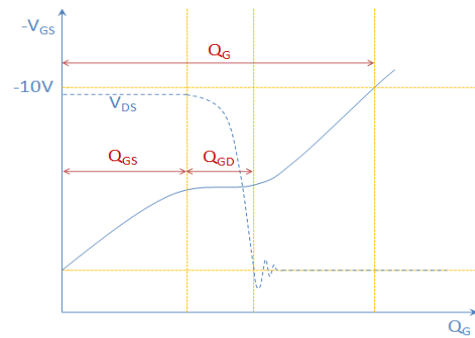
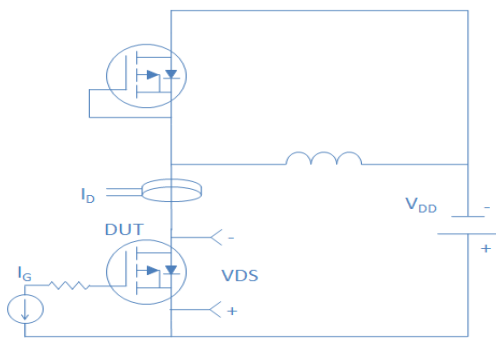

Uclamped Inductive Switching (UIS) Test

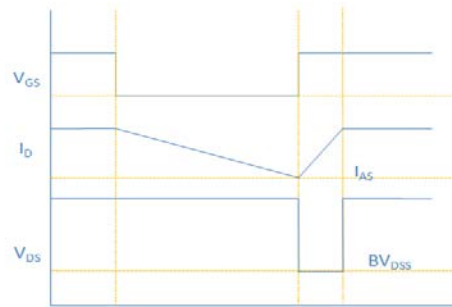
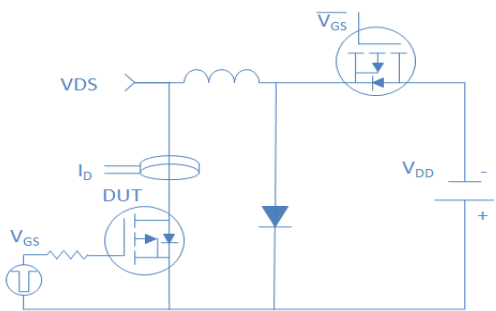

Diode Recovery Test

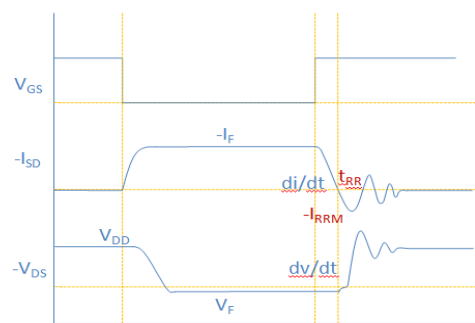
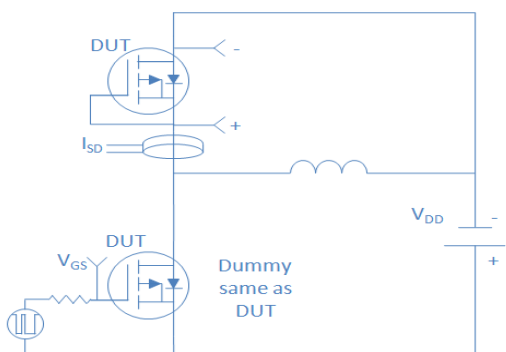

Package Outline

SOIC-8, 8leads

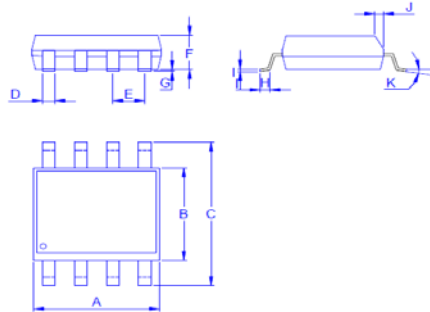

Dimension	A	B	C	D	E	F	G	H	I	J	K
in.	4.70	3.70	5.80	0.33		1.20	0.08	0.40	0.19	0.25	0°
Typ.					1.27						
Max.	5.10	4.10	6.20	0.51		1.62	0.28	0.83	0.26	0.50	8°